

ADDISON PRO QR CODE LED CIRCULAR LUMINAIRE INSTRUCTIONS Issue 02 on 28th February 2024

THANK YOU for buying this product. To help ensure it gives complete satisfaction please install it according to these instructions and then pass the instructions to the appropriate person for retention and future reference.

SAFETY This is a mains powered product. It is designed to be installed by suitably qualified personnel only and in accordance with the applicable building and electrical regulations. Before installation or maintenance the electrical supply to the product must be isolated.



INSTALLATION SUPPORT If installation advice or accessories are required please contact us at the above address. We will do our best to help. When reporting a suspected fault or seeking installation support the problem is likely to be resolved most quickly if you have full product details to-hand, as well as details of when and where it was purchased.

INSTALLATION

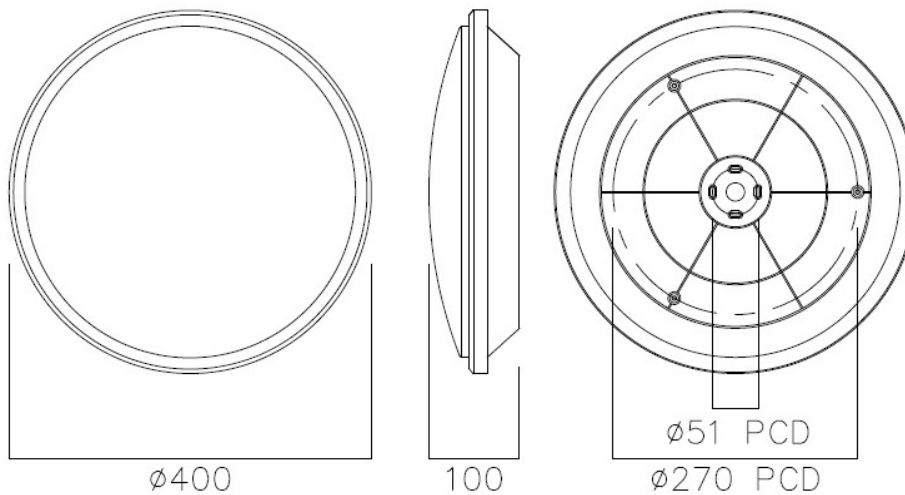

1. Unclip the trim to access the diffuser
2. Remove the diffuser from the base by rotating anti-clockwise to unlatch then pull away.
3. Loosen the three gear tray retaining screws, rotate the gear tray anti-clockwise to align the screw heads with the large aperture of the keyhole slots & remove the gear tray away from the base.
4. Prepare the mains supply cable & fixing points on the chosen mounting surface ensuring it is able to retain the weight of the luminaire.
5. Pass the mains supply cable through the entry hole provided in the base, offer the base to the mounting surface & secure using the screws provided.
6. Route the mains supply cable to the terminal block on the gear tray & terminate ensuring correct polarity is observed. **WARNING: THIS LUMINAIRE MUST BE EARTHED**
7. Secure the supply cable using the clamp provided on the gear tray.
8. Refit the gear tray & secure by retightening the screws.
9. Select the required CCT Selectable option by sliding the switch on the side of the gear tray to the allocated colour.
10. Refit the diffuser by placing over the base & rotating clockwise until it locks into position.
11. Reclip the trim by aligning the pegs & push to clip into place
12. Reconnect power supply & check for correct operation.

N.B. Luminaires fitted with electronic drivers are exempt from insulation resistance tests as this may cause damage to the driver.

MAINTENANCE

1. Cleaning should be carried out at regular intervals so as not to impair photometric performance or thermal safety of the luminaire.

GENERAL MAINTAINED EMERGENCY LUMINAIRE INSTRUCTIONS

These instructions should be followed in conjunction with the standard luminaire instructions. Please read carefully and pass to the end user/responsible person for retention and future reference.

INSTALLATION

1. Following the installation of the luminaire in accordance with the standard luminaire installation instructions, a separate permanent live supply should be terminated in the incoming supply terminal block in the luminaire, in the connection marked 'L PERM'. The permanent supply **MUST** be taken from the same phase as the corresponding switched supply and **MUST** be wired at the switchboard so that upon instances of tests, it is isolated at the same time as the switched supply.
2. Once the permanent live supply is connected, connect the battery to the module via the 'plug and mate' connector, ensuring correct polarity is observed. Failure to observe correct battery polarity will result in permanent damage to the emergency module/driver.
3. N.B. to avoid potential damage to the battery please ensure the permanent live is energized as soon as possible following connection of the battery to the module.
4. Upon restoration of the power supply to the luminaire, check that the indicator LED fitted within the luminaire illuminates green. This indicates that the batteries are charging and that the charging circuit is healthy.
5. Allow the battery to charge for an uninterrupted period of not less than 24 hours prior to carrying out a full discharge test.

MAINTENANCE

6. The battery pack in this luminaire must be replaced when it is no longer able to satisfy its full rated duration.
7. In emergency mode the light level of the luminaire will be at a reduced output. Regular maintenance and gentle cleaning are recommended so as to ensure that the Emergency Output Factor (E.O.F) remains at specified levels.
8. Isolate the supply before servicing.
9. Please ensure that the emergency flux is not compromised at any time throughout the luminaires design life.
10. **DO NOT INSULATION TEST**

Caution:

The battery pack in this luminaire is a Lithium Iron Phosphate (LiFePO₄) type which includes a dedicated protection circuit. If replacing the battery pack, the specification and chemistry must be identical to that detailed on the battery label.

TESTING OF EMERGENCY LUMINAIRES:

Recommended routine test procedures in line with BS 5266-1:2016 & BS EN 50172:2004.

MICROWAVE SENSOR C/W DIP SWITCHES INSTRUCTIONS (FOR PRODUCTS WITH SUFFIX .../MW)

These instructions are in addition to the standard luminaire instructions that were also supplied with the product you have purchased. They should be read carefully & luminaire installed as per both sets of instructions, then pass on to the appropriate person for retention for future reference & maintenance.

DESCRIPTION

The NVC micro-wave sensor option offers presence detection to provide automatic control of lighting loads. It is installed inside the luminaire so does not affect external aesthetics or IP rating. Manual adjustments on the sensor allow it to be individually tailored to suit your application.

POSITIONING

The luminaire with detector should be sited so that the occupants of the room fall inside the detection patterns shown in the appropriate diagram below:

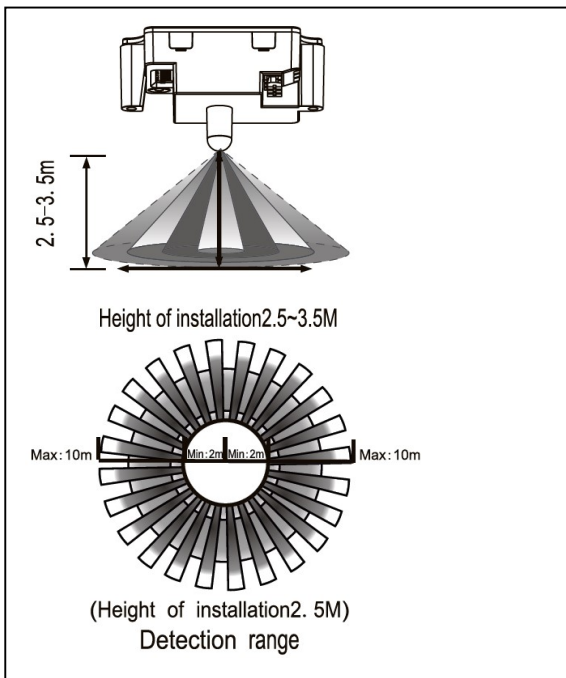

- The diagram is based on a ceiling mounting height of 2.5m. Note that the lower the sensor is installed, the smaller the detection range will be.
 - If wall mounted, the detection zone will vary depending on the surroundings but perpendicular reach will be at least 10m
 - The area closest to the sensor & also the area more perpendicular to the sensor will have higher sensitivity.
 - The distances quoted are approximate & may vary depending on surroundings
 - Avoid direct sunlight entering the sensor.
 - Do not site within 1m of forced air heating or ventilation.
 - Do not fix to a vibrating surface.
 - Avoid metallic objects directly in front of the sensor head.
 - These sensor kits are capable of switching/controlling more than one luminaire in a 'master & slave' set up. This is done by linking non-sensored fittings (slaves) to the one with the sensor fitted (master) using the live output from the sensor.
- Note! DO NOT** link other fittings containing MW sensors together in this way, as it can cause false triggering of the sensors.

SETTINGS

The following adjustments can be made using the DIP switches located on the sensor unit.

DEFAULT FACTORY SETTINGS...

Sensitivity – 10m Time – 20mins Lux – 24H (lux level control disabled)

1. SENSITIVITY

Set the detection range using the S1 & S2 DIP switches as shown below.

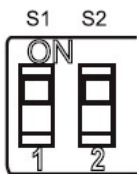

SENS: S1, S2

S1	S2	detection range
0	0	2m
0	1	5m
1	0	8m
1	1	10m

N.B. DIP switch ON position=1

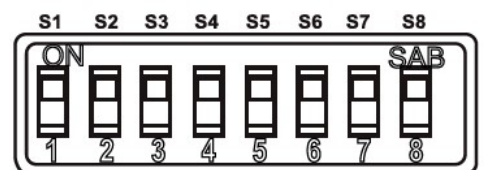

2. TIME

Set the required time delay between 10 secs - 30 mins using S3, S4 & S5 DIP switches as shown below:

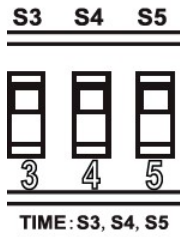

S3	S4	S5	TIME
0	0	0	10s
0	0	1	1min
0	1	0	5min
0	1	1	10min
1	0	0	15min
1	0	1	20min
1	1	0	25min
1	1	1	30min

3. LUX

Set the required Lux level by using S6, S7 & S8 DIP switches as shown below.

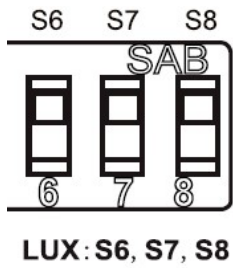

S6	S7	S8	LUX
0	0	0	24H
0	0	1	10LUX
0	1	0	20LUX
0	1	1	50LUX
1	0	0	100LUX
1	0	1	200LUX
1	1	0	300LUX
1	1	1	500LUX

RATINGS

Power supply	220-240VAC 50/60Hz
Transmission Power	<0.2mW
Rated Load	1000W
Power Consumption	0.5W approx.

FAULT FINDING

If you experiencing a problem please check through the following before making contact with NVC:

Fault - Load does not come on

- Check to see if the live supply to the circuit is good.
- If the supply & wiring are good, check the LUX setting. Increase the LUX level setting to allow the sensor to turn on at a higher ambient light level.

Fault - Lights do not go off

- Ensure that the area is left unoccupied for longer than the selected timer setting.
- Make sure that the sensor is not adjacent to circulating air, heaters or lamps.
- If the unit "false triggers" reduce the SENSITIVITY level to narrow the area of detection.
- Ensure luminaire is not connected in parallel with other luminaires containing MW sensors

DD DIMMING VERSIONS ONLY

TYPE OF DIMMING

This product uses a LED driver that is capable of 2 methods of dimming:

DALI

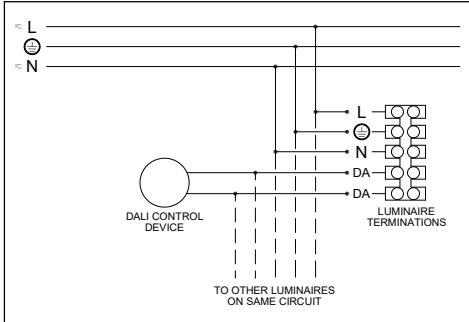

Dimming via a Digital Addressable Lighting Interface.

Note! Further input may be required from your lighting controls provider.

SWITCH-DIM

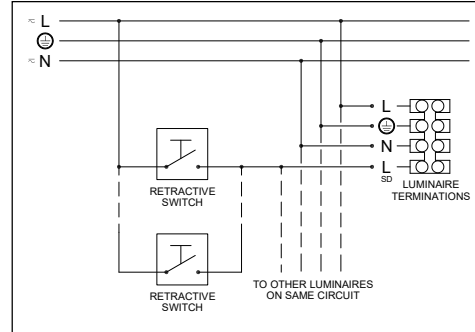

Dimming via a retractive switch.

Note! Different makes of control gear should never be actuated by the same retractive switch in an installation. There is a risk of a conflict in what you are asking the ballast to do.

REMOTE DRIVER WIRING

Power supply & signal wires input for luminaires with remote mounted LED drivers (i.e. driver not inside luminaire).

Note! The make of LED driver will need to be identified so the correct wiring can be followed.

Luminaires using OSRAM QTI DALI

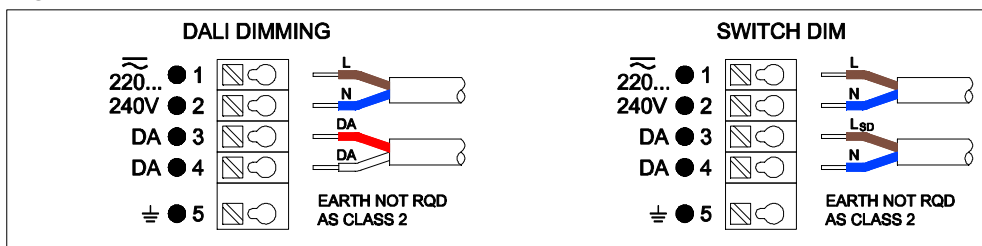

Note: L_{SD} = Switch Dim Live

Luminaires using TRIDONIC ECO SR

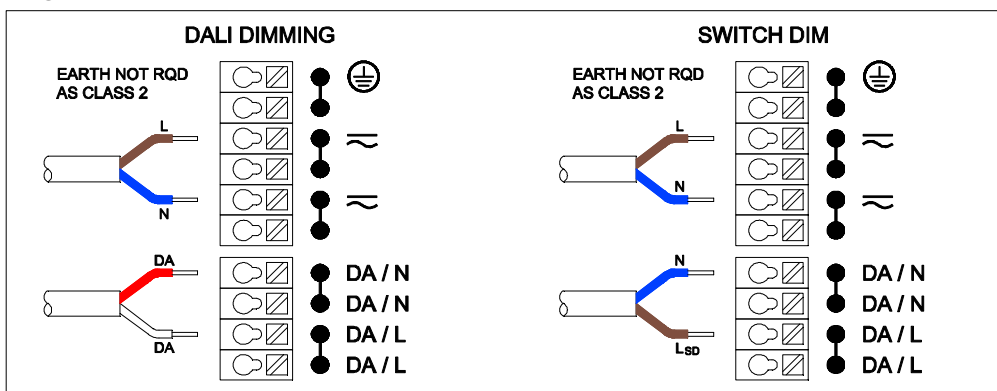

Note: L_{SD} = Switch Dim Live

Luminaires using PHILIPS XITANIUM

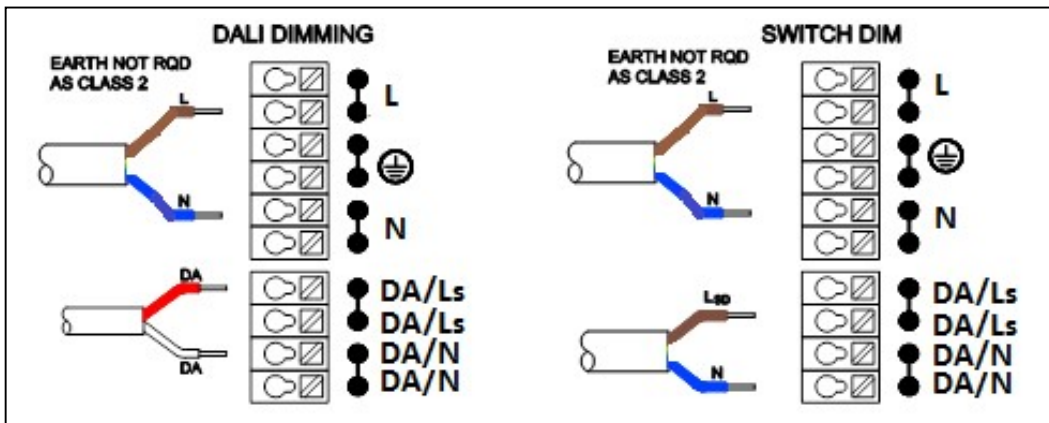

Note: L_{SD} = Switch Dim Live

INTERNAL DRIVER WIRING

Power supply & signal wires input for luminaires with built in LED driver & where there is a terminal block present

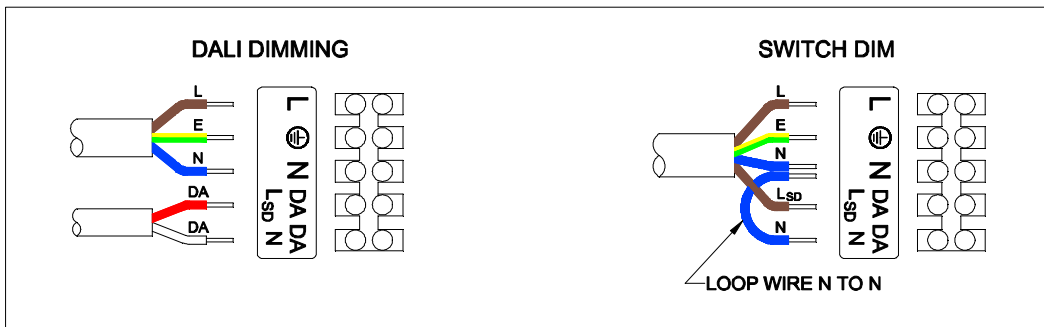

Note: L_{SD} = Switch Dim Live